

SI-1166A 1800R.P.M. Screw Driver Adjustable Clutch

SI-1166-8A 800R.P.M. Screw Driver Adjustable Clutch

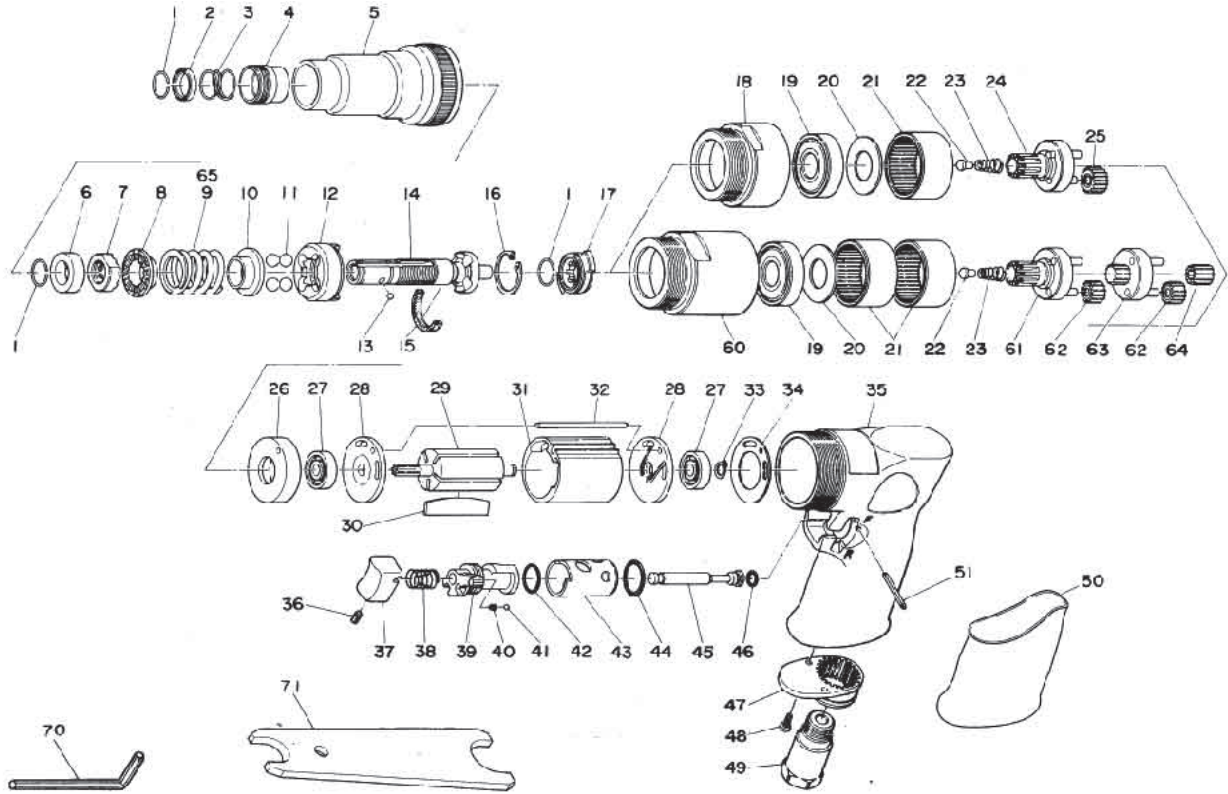

Ref. No.	Parts No.	Description	Q'ty	Ref. No.	Parts No.	Description	Q'ty
1	950-1-1	Retaining Ring	3	31	217-15	Cylinder	1
2	950-1-2	Washer	1	32	200-34	Cylinder Pin	1
3	950-1-3	Chuck Sleeve Spring	1	33	JS-6	Retaining Ring	1
4	950-1-4	Chuck Sleeve	1	34	217-32	Motor Gasket	1
5	210-1-5	Clutch Housing	1	35	217-1A	Motor Housing	1
6	950-1-6	Spacer	1	36	R-M40-60	Set Screw	1
7	950-1-7	Adjust Nut	1	37	120-18	Trigger	1
8	950-1-8	Spring Seat	1	38	120-31	Valve Spring	1
9	950-1-9	Clutch Spring	1	39	217-5	Reverse Lever	1
10	950-1-10	Thrust Washer	1	40	217-44	Rubber Cushion	1
11	SB-1/4	Steel Ball	4	41	SB-25	Steel Ball	1
12	950-1-12	Clutch Carrier	1	42	990-26-1	O-Ring	1
13	SB-1/8	Steel Ball	1	43	217-6	Reverse Bushing	1
14	950-1-14	Cam Spindle	1	44	P-14	O-Ring	1
15	950-1-17	Wiper	1	45	217-3	Valve Stem	1
16	JO-21	Retaining Ring	1	46	P-4	O-Ring	1
17	950-1-16	Drive Dog	1	47	120-11	Deflector	1
18	217-20	Clamp Nut	1	48	JBM30-80	Screw	2
19	6201-Z	Ball Bearing	1	49	120-17SC	Inlet Bushing incl. Screen (690-28A)& Retainer(CRTW-12)	1
20	957-35	Washer	1	50	217-45	Housing Cover	1
21	217-10A	Internal Gear	1 (2)	51	25-24	Roll Pin (2.5 ϕ -24mm)	1
22	957-30	Guide Pin	1	★ 60	217-8-1	Clamp Nut	1
23	217-22	Guide Pin Spring	1	★ 61	217-8-7	Work Spindle incl. Pins (300-21 \times 3)	1
24	217-13	Work Spindle incl. Pins (300-21 \times 3)	1	★ 62	217-8-2	Planet Gear incl. Bush (217-8-3)	6
25	217-12	Planet Gear incl. Bush (217-33)	3	★ 63	217-8-5	Reduction Spindle incl. Pinion & Pins (217-8-6, 300-21 \times 3)	1
26	217-18	Spacer	1	★ 64	217-B-4	Pinion Gear	1
27	626	Ball Bearing	2	★ 65	950-1-20	Clutch Spring	1
28	217-14	End Plate	2	70	WRA-1/4	1/4" Allen Wrench	1
29	217-17	Rotor	1	71	330-28	Spanner Wrench (11 \times 17mm)	1
30	350-16	Rotor Blade	5	※ 72	181-51A	+Bit No.2	1